

Thank you for purchasing a Sealey product. Manufactured to a high standard this product will, if used according to these instructions and properly maintained, give you years of trouble free performance.



**IMPORTANT: PLEASE READ THESE INSTRUCTIONS CAREFULLY. NOTE THE SAFE OPERATIONAL REQUIREMENTS, WARNINGS & CAUTIONS. USE THE PRODUCT CORRECTLY AND WITH CARE FOR THE PURPOSE FOR WHICH IT IS INTENDED. FAILURE TO DO SO MAY CAUSE DAMAGE AND/OR PERSONAL INJURY, AND WILL INVALIDATE THE WARRANTY. PLEASE KEEP INSTRUCTIONS SAFE FOR FUTURE USE.**

### 1. SAFETY INSTRUCTIONS

- ✓ Familiarise yourself with the application and limitations of the hose reel, as well as the specific hazards.
- ❑ **WARNING!** Disconnect the hose reel from the water supply before changing accessories, servicing or performing any maintenance.
- ✓ Maintain the hose reel in good condition (use an authorised service agent).
- ✓ Replace or repair damaged parts. *Use recommended parts only. Unauthorised parts may be dangerous and will invalidate the warranty.*
- ✓ Locate and fix the hose reel in a suitable working area. Do not position the hose in direct sun light, or in areas of extreme heat or cold. Ensure there is adequate lighting.
- ❑ **WARNING!** Ensure maximum water pressure is not exceeded.
- ✓ Keep extended air hose away from heat, oil and sharp edges. Check hose for wear before each use, and ensure all connections are secure.
- ✓ Maintain correct balance and footing. Ensure the floor is not slippery and wear non-slip shoes.
- ✓ Remove ill fitting clothing. Remove ties, watches, rings, and other loose jewellery and contain and/or tie back long hair.
- ✓ Keep children and unauthorised persons away from the working area.
- ✗ **DO NOT** operate the hose reel if any parts are damaged or missing as this may cause failure and/or personal injury.
- ✗ **DO NOT** exceed the rated capacity of the hose reel.
- ✗ **DO NOT** use the hose reel for any purpose other than that for which it is designed.
- ✗ **DO NOT** operate the hose reel when you are tired or under the influence of alcohol, drugs or intoxicating medication.
- ✓ When not in use ensure the water supply is turned off and tools disconnected. Disconnect from water supply and retract hose into case.
- ❑ **WARNING! DO NOT** dismantle the hose reel casing, or attempt to remove the screws and covers on the sides. *To do so may result in damage to the appliance and/or personal injury and will invalidate the warranty. Internal maintenance, which will require the opening of the casing, must only be undertaken by an authorised service agent.*

### 2. INTRODUCTION & SPECIFICATION

Tough, impact resistant, durable, composite case with wall/ceiling mounting bracket. Fitted with 18mtr high quality PVC hose. Complete with 2mtr leader hose and water gun.

Hose Length: .....	18mtr	Hose Type: .....	PVC garden hose
Hose Size (ID): .....	12mm	Inlet: .....	½" BSP
Max. Pressure: .....	14bar/203psi		

### 3. INSTALLATION

- ❑ **WARNING! Do not position the reel in areas of extreme heat or cold.**
- NOTE: Prolonged exposure to direct and intense sunlight may affect the integrity of the polymers within the moulded components. Avoid, if possible, positioning the reel in direct sunlight.**

#### 3.1 MOUNTING THE REEL

- 3.1.1 Due to the way the retractable hose operates, the reel should only be mounted in one of two positions shown below. The brackets supplied will enable you to mount the reel in either position.
- 3.1.2 Ensure the wall, ceiling or other structure, to which the hose reel is to be fixed, is of sound construction and that the securing points will hold the working strain of the hose when in use.
- 3.1.3 Using the mounting holes template (cut from box lid), drill appropriate holes for the desired mounting or see diagram below.
- 3.1.4 When wall mounted the hose exit point should not be more than 2.4 mtrs above floor level. Above this height ceiling mounting is recommended. See diagrams below.
- 3.1.5 Screw fix one bracket to the chosen surface using fixings that are appropriate to the substrate and strong enough to carry the weight of the reel plus the working strain exerted on it when in use. Position the hose reel onto the first bracket, then proceed to fix the second bracket into place and ensure the reel is secure.

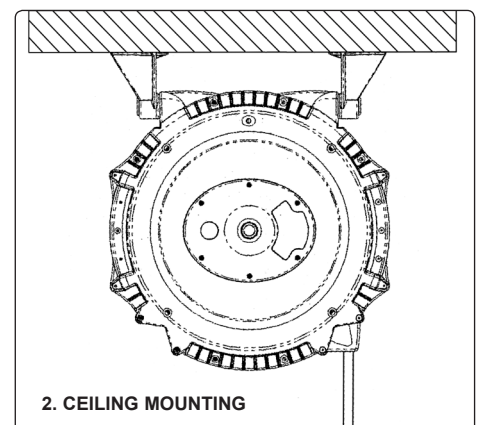
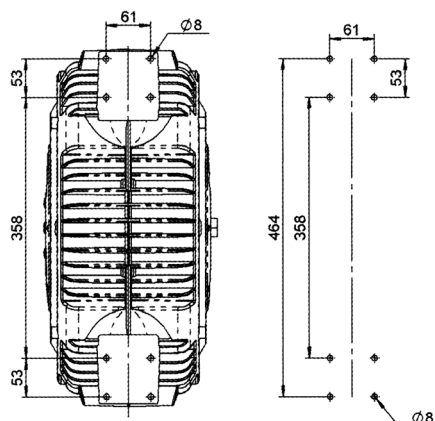
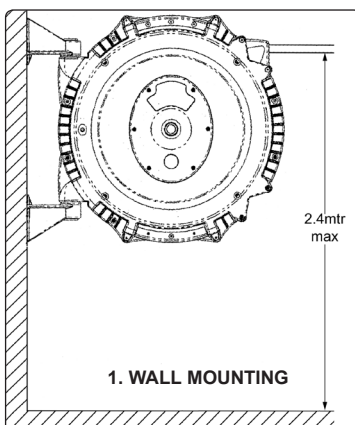

## 4. OPERATION

- 4.1 Pull out the hose to the required length. A clicking noise will be heard every half revolution of the drum.
- 4.2 To latch the reel, allow the reel to slowly retract after hearing the 1st, 2nd or 3rd click.
- 4.3 To unlatch the reel, slowly pull out the hose until the clicking noise stops, then let the hose slowly retract until the hose stopper rests against the reel mouth.

NOTE: Remove tools from the hose when they are no longer required for use.

- WARNING! To prevent injury or damage occurring, do not let go of the hose during rewinding.**

## 5. MAINTENANCE & STORAGE

- WARNING! Before carrying out routine maintenance or inspection, vent any pressure remaining in the hose.**
- 5.1 The hose reel does not require special maintenance as it is lubricated for life. To ensure reliable operation, clean the hose and casing regularly. **DO NOT** spray or wet the product, but clean with a cloth and warm water. **DO NOT** use solvents or detergents, as these may permanently damage the plastic.
- 5.2 There are no user serviceable parts. All maintenance and repairs which require the case to be opened or dismantled should be carried out by an authorised service agent only.
- WARNING! DO NOT dismantle the hose reel casing, or attempt to remove the screws and covers on the sides. To do so may result in damage to the appliance and/or personal injury and will invalidate the warranty.**

### STORAGE:

Should you wish to store the hose, ensure it is clean and dry. Place the item in a dark, safe, dry, childproof location, where the temperature will remain reasonably stable. **DO NOT** store in a nylon or plastic bag, as this will encourage condensation.

## 6. TROUBLESHOOTING

PROBLEM	POSSIBLE CAUSE	SOLUTION
Hose will not retract:	Hose bunching within reel. Spring tension too tight. Replacement hose too heavy.	Pull hose out of reel and guide back in. Have spring tension adjusted by authorised service agent. Have correct hose fitted by authorised service agent.
Reel will not latch:	The hose has been pulled past the latching teeth. Broken latching pawl or pawl spring.	Allow reel to retract slowly after hearing 1st, 2nd or 3rd click. Have new latching pawl or pawl spring fitted by authorised service agent.
Reel leaks:	Damaged hose.	Have new hose fitted by authorised service agent.



**NOTE:** It is our policy to continually improve products and as such we reserve the right to alter data, specifications and component parts without prior notice.

**IMPORTANT:** No liability is accepted for incorrect use of this product.

**WARRANTY:** Guarantee is 12 months from purchase date, proof of which will be required for any claim.

**INFORMATION:** For a copy of our latest catalogue and promotions call us on 01284 757525 and leave your full name and address, including postcode.



Sole UK Distributor, Sealey Group,  
Kempson Way, Suffolk Business Park,  
Bury St. Edmunds, Suffolk,  
IP32 7AR

